

Advanced Sewage Treatment Systems

Sequence Batch Reactor (SBR) Technology

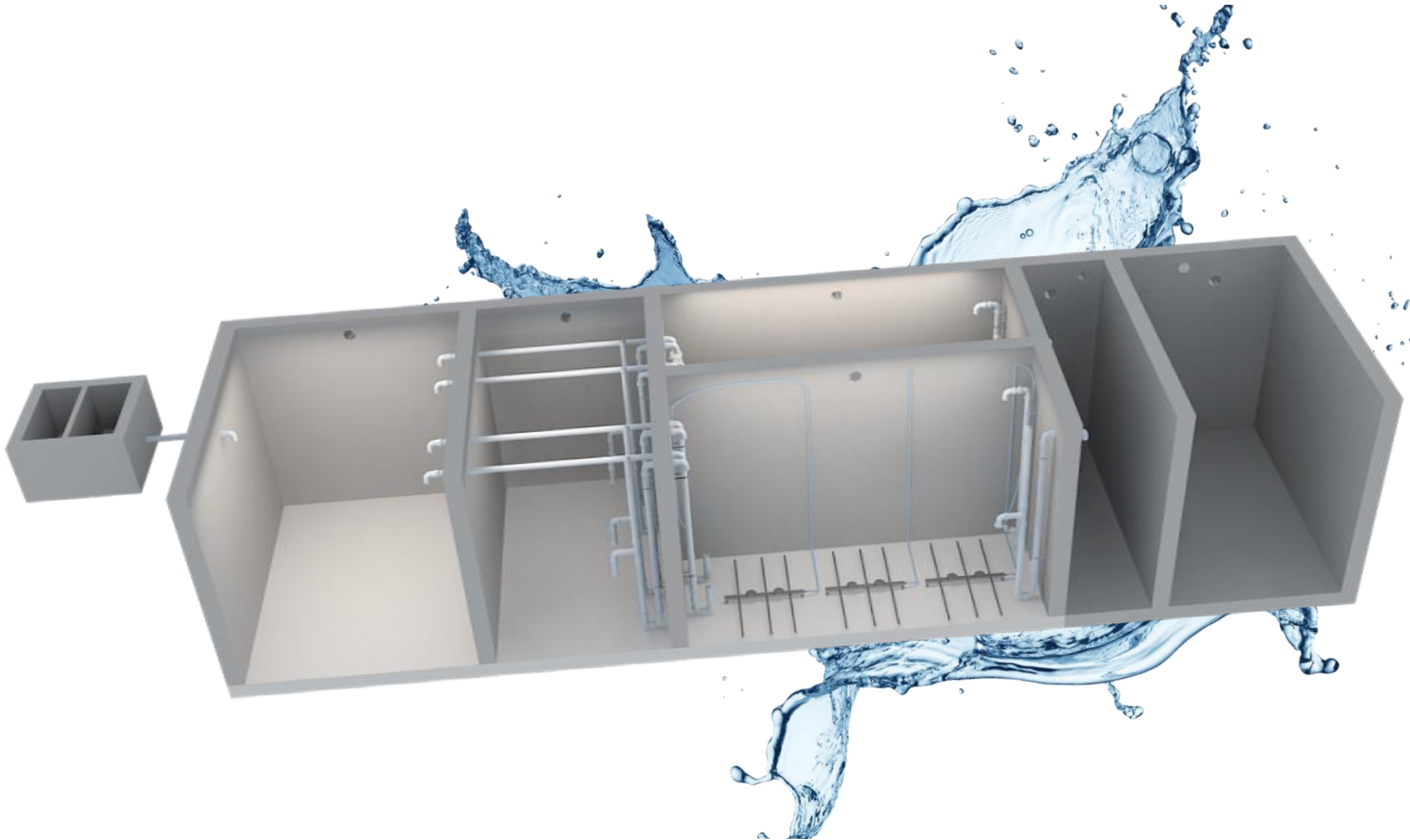

No electrical connection in wastewater



No regular operator needed



No chemicals in treatment process

Over 350,000 people treat their Sewage water with EcoTec EcoSBR systems!

Rely on market leader in small waste water treatment systems with Air-lift principle

EcoTec means.....



Channel Partners provide the required service and maintenance of our high quality systems. Channel partners are trained to care for EcoSBR systems.



EcoSBRcompact fully automated external cabinet with control system

Air-Lift Technology!

Wastewater from one tank to another tank is pumped with EcoTec's intelligent Air-Lift arrangements. Air-Lift Pumps are safer and reliable solutions when compared to electro mechanical pumps. Air-Lift Pumps do not need electrical connections and there are no wear and tear parts.

EcoTec Benefits

- Centralized design & production ensures high quality of each plant
- Non compromising design principles ensures high performance
- High quality component ensures long life of plant
- Flexible design can be made according to site conditions
- Technology can be retrofitted in existing STP with minor modification
- Under load operation in ecoSave mode saves money
- No minimum load needed for operation and performance
- Fully-biological mode of operation
- Minimal power consumption
- Maximum treatment with minimum processes
- Reuse and recycle with minimum tertiary treatment.
- No odour!, extremely high customer satisfaction levels
- Treatment levels surpass PCB requirements
- Installation and commissioning done within a few days
- Short delivery times once ordered
- Trouble shooting and service of plant carried out by our experienced personnel

EcoTec EcoSBR Treatment and Efficiency

Household activities in water usage involve kitchen usage, washing, laundry, bathing and flushing the toilets. This combined water is characterized as sewage water. EcoTec EcoSBR plants are designed to treat this wastewater.

EcoSBR series of sewage treatment plants are designed as per German Standard DWA ATV 126, ATV-DVWKA 131.

Depending on the need for reuse and recycle additional tertiary treatment can be added to our standard EcoSBR sewage treatment plants.

EcoSBR Plants are designed to achieve high levels of treatment before tertiary treatment. The treatment values achieved are as below,

Sewage parameter	At Inlet	EcoSBR Values	EcoSBR Efficiency
COD (chemical oxygen demand)	800 mg/l	40 mg/l	95%
BOD ₅ (biochemical oxygen demand)	400 mg/l	9 mg/l	98%
SS (suspended solids)	467 mg/l	20 mg/l	96%
NH ₄ -N (ammonium nitrate)	73 mg/l	3.5 mg/l	90%

Each treatment plant is designed to achieve high levels of treatment with optimal energy usage. EcoSBR series consumes the least energy for the treatment, while according to site conditions there might be slight variation in power consumption. The below illustration is the power consumption/ person in a year with EcoSBRcompact plant.

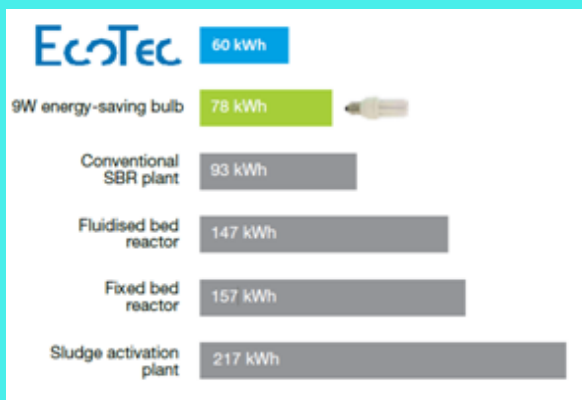

EcoSBR Process

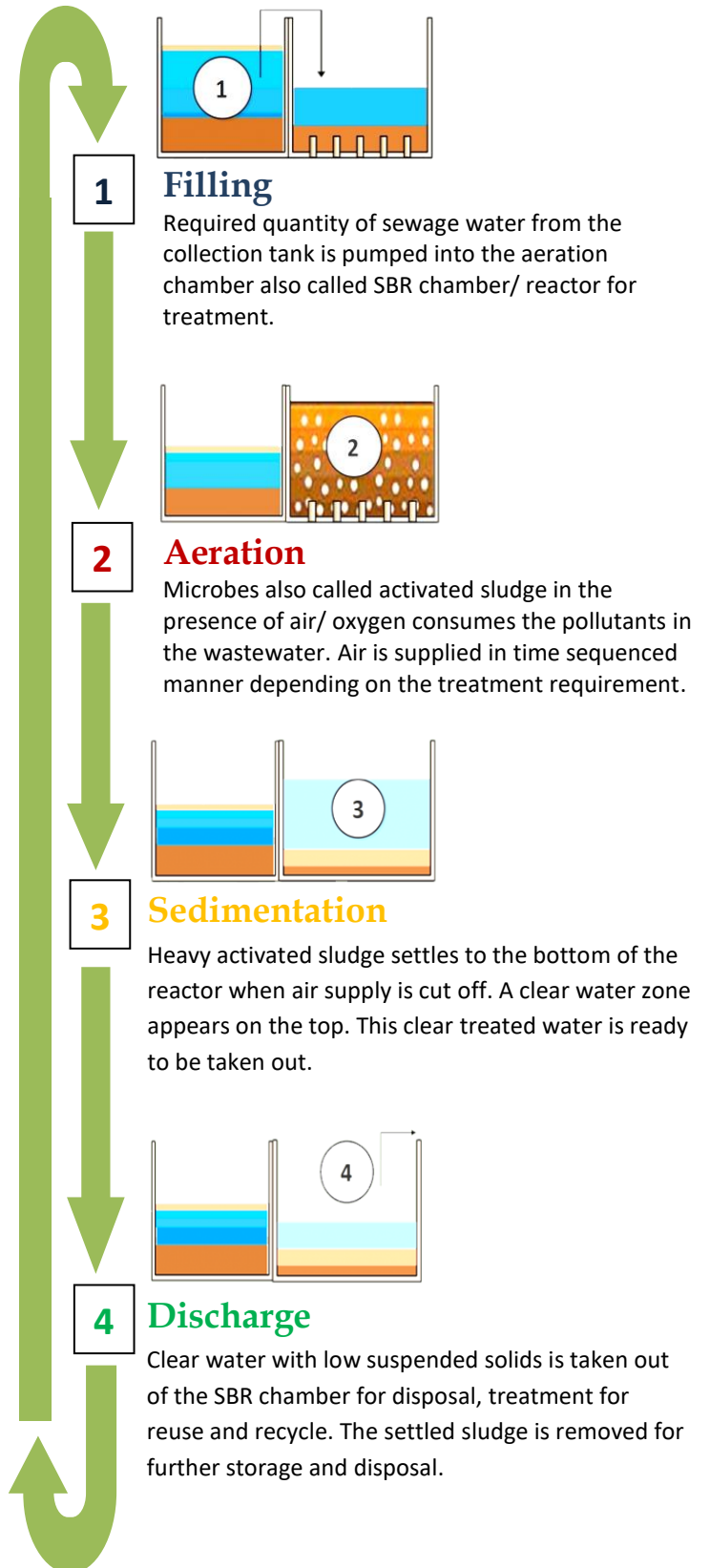



Treatment solution for single home from 4 people & up to a cluster of homes of 20 people.

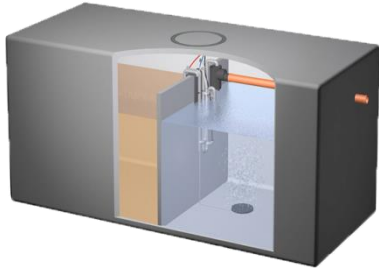

- can be fitted into fully underground tanks on site
- No replaceable pumps or moving parts in wastewater tank
- No valves in water for decantation
- One air-pump does the work of sewage transfer pump, aeration, sludge recycle and also decanting
- Easy to operate and maintain controller and air pump machine cabinet
- Very low power consumption in a day
- Operation is not hampered by frequent power cuts



For small communities from 5 families and up to 50 dwelling units

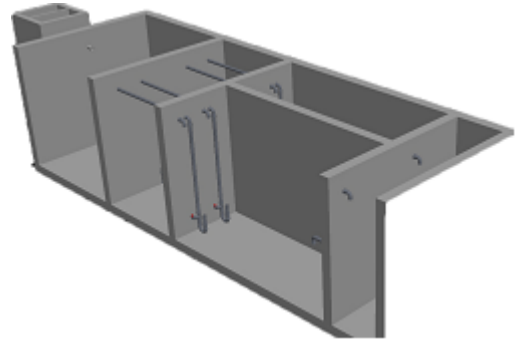

- Fully automatic operation
- No operator required
- Can be retrofitted into underground septic tank (design from EcoTec)
- Airlift pump replaces electrical pump and mechanical decanters
- Very high efficiency in operation: just one compressor does the job of 4 pumps and blower
- Very low operation and maintenance cost
- Ecosave mode takes care of low load and weekend operations
- Long life product



Modular approach for larger treatment plant 100 KLD to 500 KLD

- Low initial investment for owners and operators in projects that are planned in phased development
- High performance even in very low loading
- Low power consumption in low occupancy period
- Can be upgraded when higher than treatment capacity is reached
- Seasonal, weekend, daily load variation is intelligently managed by Ecosave mode
- Suitable for real estate projects, industrial parks, commercial buildings, resorts, schools, hospitals, etc

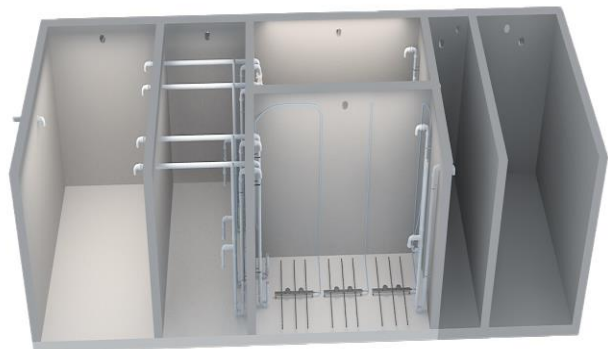



130 KLD EcoSBR plant in an educational institute-Chennai

Intelligent Process design adaptation saves your future expenditure and energy!

Ecosave mode: Saves energy consumption!

When there is low occupancy or sometimes no occupancy, the flow into the sewage treatment plant is reduced. During this period the plant need not work in its full treatment capacity but needs to be operated according to the incoming load.

EcoTec Ecosave mode is an intelligent process that operates the plant by supplying just enough air to keep the microbes in surviving conditions. The collection tank levels are checked at regular interval for inflow, if there is adequate inflow the plant switches to normal treatment mode else Ecosave mode continues.

Customized and intelligent design!

Each building type requires special design and EcoTec experts know it better than anyone. Typical household and office do not have same design due to water usage pattern. In an office with only 8 working hours in a day, there is very high consumption during the early hours and in the time before closing for the day. This water has to be treated over 24 hours by evenly distributing in batches. EcoSBR systems are designed to accommodate such flow on a daily basis and also go into Ecosave mode during weekends.

When there is stricter regulation to comply, EcoSBR plants can be upgraded with minimum modification.

EcoSBR for all your special needs!

Commercial buildings, factories, resorts, weekend homes, restaurants, hotels, banquets, hospitals, day schools, residential colleges have varying load conditions. EcoSBR systems are designed according to each of these special needs.

EcoSBR due to its batch operation is suitable for any application and every building type. EcoSBR automatic operation gives you peace of mind: you do not have to depend on operator.

EcoSBR control and error messaging give the customer the right information on failures for relevant and appropriate action.

EcoTec Strength

Highest number of SBR plants operational in India!

EcoTec has been pioneer in India for SBR with Air-Lift pumps. No matter what your building type is, EcoTec has the design and solution for your sewage and waste water treatment. More than 150,000 users have put their trust in EcoTec for their wastewater treatment. Our systems are operational in remote locations such as Badhrinath, Kashmir and even in remote Andaman Island resorts. Our expert engineers and technicians have the right knowledge and experience to support each of your need. Our flexible approach and yet uncompromising design has been secret to our success.

EcoTec trained and qualified channel partners are available in different parts of the country provide the required sales, installation, commissioning, service and maintenance support to EcoTec customers. You can rely on EcoTec for,

Delivery

Our delivery is scheduled in line with your project planning. We can deliver your requirement before even other companies start their procurement for components.



Installation & Commissioning



Our qualified and trained technicians ensure that all the parts are fitted in your site properly as per design. Our technicians also know that they have to be prepared for the unexpected and make relevant modifications according to site conditions during installations. Our flexible design and production comes handy at every stage and installation is done in just days.

Operation and Maintenance

Our manuals give full detail of the plant design and its functionality. Each operation of the plant can be modified according to site conditions and treatment requirement by referring the manual. With EcoSBR series you can to have a head ache free operation of your sewage treatment system. The operation manual contains the respective plant service and maintenance plan schedule. The controller sends critical alarms when the time for service approaches. EcoTec experts are always willing to visit and check the plant operation for you. EcoTec support at all times with analysis keeps you up to date with your plant performance any time.



EcoTec Engineers and Consultants
2/54B, Mookiah Gardens,
Off East Coast Road,
Muttukadu
Chennai – 603 112,
India

Contacts:

Email: sales@ecotec.in

Phone: +91 44 27472006

