

JetFlex® TD 65-2 G Tube Diffuser





Dimensions

Material	Tube diameter	ID-Sleeve	Wall thickness
EPDM	63 mm	~ 65 mm	1.9 ± 0.15 mm
Silicone	63 mm	~ 65 mm	1.5 ± 0.15 mm
PUR	63 mm	~ 65 mm	0.75 ± 0.025 mm



Installation drawing

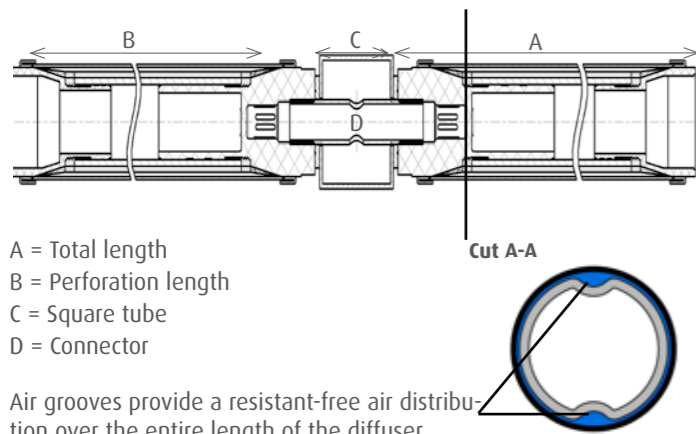

SSOTE and headloss for EPDM 1000 mm

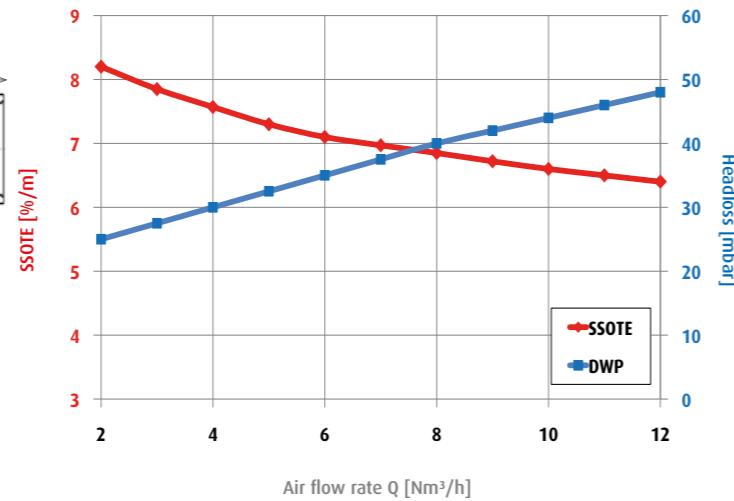

Perforation length [B]	Total length [A]	Perforated area		Air flow rate at standard operating conditions		Max. overload / maintenance air flow rate		Operating mode
		EPDM	SI+PU	EPDM + SI	PU	EPDM + SI	PU	
1000 mm	1080 mm	0.18 m²	0.16 m²	2 - 12 Nm³/h	3 - 8 Nm³/h	20 Nm³/h	16 Nm³/h	continuous / intermittent
750 mm	830 mm	0.135 m²	0.12 m²	1.5 - 9 Nm³/h	2 - 6 Nm³/h	15 Nm³/h	12 Nm³/h	continuous / intermittent
500 mm	580 mm	0.09 m²	0.08 m²	1 - 6 Nm³/h	1 - 4 Nm³/h	10 Nm³/h	8 Nm³/h	continuous / intermittent

Dimensions for connection to square pipes

Connector [D]	Connector length square tube 80 x 80 mm [C]	Connector length square tube 100 x 100 mm [C]	Drill hole for connector
Pipe thread ISO 228 - G 1A	145 mm	165 mm	35 +1/-0 mm
Pipe thread ISO 228 - G 3/4A	145 mm	165 mm	28 +1/-0 mm

Please see our operation manuals for more details.



Membrane materials

Material	Techn. standard	EPDM	PUR	Techn. standard	Silicone
Colour		black	transparent		translucent
Plasticiser (%)		35	0		0
Density (g/cm³)	DIN EN ISO 1183-1	1.11	1.13	DIN EN ISO 1183-1	1.16
Tensile strength (N/mm²)	DIN 53504	>7	>45	DIN 53504	>9
Elongation at break (%)	DIN 53504	>400	>450	DIN 53504	>900
Tear strength (N/mm)	DIN EN ISO 34-1	>7,5	>35	ASTM D 624 B	>38
Hardness (Shore A)	DIN ISO 7619-1	40 ± 5	80 ± 5	DIN 53505	60 ± 5
Operating air temperature (°C)		5 - 80	5 - 60		5 - 100
Operating water temperature (°C)		5 - 40	5 - 40		5 - 40

Other materials

Support tube	SS clamp
PP / PP 20% GF	1.4301

Accessories



Please see our accessories catalogue for more details.



Jäger Umwelt-Technik GmbH

Ruscheplattenstraße 14

31137 Hildesheim

Germany

+49 5121 9138 900

+49 5121 9138 999

info@jaeger-envirotech.com

www.jaeger-envirotech.com



Disclaimer

We exclude any liability for the information and product presentations provided. Contents of technical character are based on the date of publication. Existing copyrights and rights to the use of names remain unaffected.

